

LM5022 Evaluation Board

National Semiconductor
Application Note 1557
Chris Richardson
May 22, 2008



Specifications Of The Board

The Evaluation Board has been designed for testing of various circuits using the LM5022 boost regulator controller. A complete schematic for all the components is shown in *Figure 3*. The board is two layers with components and power paths in 1oz. copper. The board is 62mil FR4 laminate, and a complete bill of materials is listed at the end of this document.

Example Circuit

The example circuit which comes on the evaluation board delivers a $40V \pm 2\%$ output voltage at currents up to 500 mA and switches at 500 kHz. The input voltage range is optimized between 9.0V and 16.0V. The measured efficiency of the converter is 95% at an input voltage of 16V and an output current of 0.5A.

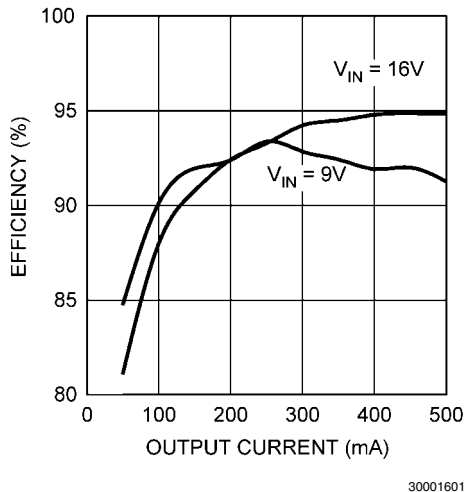

FIGURE 1. Efficiency

Powering The Converter

The example circuit for the LM5022 Evaluation Board is optimized to run at 12V, however the circuit will operate with input voltages ranging from 6.0V to 32.0V connected between the **VIN** and **GND** terminals on the right side of the board.

Loading The Converter

The example circuit will startup with no load at the output, and can also start up with loads of up to 0.5A as long as the input voltage is above 9.0V. The maximum output current will be reduced for input voltages below 9.0V. Fixed loads, resistors, and variable electronic loads can be connected between the **Vo** and **GND** terminals on the left side of the board.

Enabling The Converter

The **OFF** terminal controls the state of the converter while power is applied to the input terminals. The LM5022 is disabled whenever the voltage at **OFF** is a logic high. (Above 2.0V.) The LM5022 is enabled whenever the **OFF** terminal is open-circuited or connected to ground, in which case startup will begin as soon as the input voltages exceeds 6.0V. Upon enabling the LM5022 will perform a soft-start, after which the output is ready to supply current to the load.

Testing The Converter

Figure 4 shows a block diagram of connections for making measurements of efficiency. The wires used for making connections at both the input and output should be rated to at least 10A of continuous current and should be no longer than is needed for convenient testing. A series ammeter capable of measuring 10A or more should be used for both the input and the output lines. Dedicated voltmeters should be connected with their positive and negative leads right at the four power terminals at the sides of the evaluation board. This measurement technique minimizes the resistive loss in the wires that connect the evaluation board to the input power supply and the electronic load.

Output voltage ripple measurements should be taken directly across the 100 nF ceramic capacitor **Cox**, placed right between the output terminals. Care must be taken to minimize the loop area between the oscilloscope probe tip and the ground lead. One method to minimize this loop is to remove the probe's spring tip and 'pigtail' ground lead and then wind bare wire around the probe shaft. The bare wire should contact the ground of the probe, and the end of the wire can then contact the ground side of **Cox**. *Figure 5* shows a diagram of this method.

MOSFET Footprints

The LM5022 evaluation board has a footprint for a single MOSFET with an SO-8 package using the industry standard pinout. (See *Figure 2*) This footprint can also accept newer MOSFET packages that are compatible with SO-8 footprints.

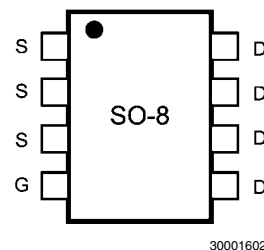

FIGURE 2. SO-8 MOSFET Pinout

Permanent Components

The following components should remain the same for any new circuits evaluated on the LM5022 evaluation board:

Name	Value
Cox, Cinx	0.1 μ F
Cf	1 μ F
Csns	1 nF
Rpd	10 k Ω
Rs1	100 Ω

Additional Footprints

The 100 pF capacitor **Csns** provides an AC input path for external clock synchronization. Detection of the sync pulse requires a peak voltage level greater than 3.8V at the RT/SYNC pin. Note that the DC voltage at RT/SYNC is approximately 2V to allow compatibility with 3.3V logic. The sync pulse width should be set between 15 ns to 150 ns by the external components. The **Rt** resistor is always required, whether the oscillator is free running or externally synchronized. **Rt** must be selected so that the free-running oscillator frequency is below the lowest synchronization frequency.

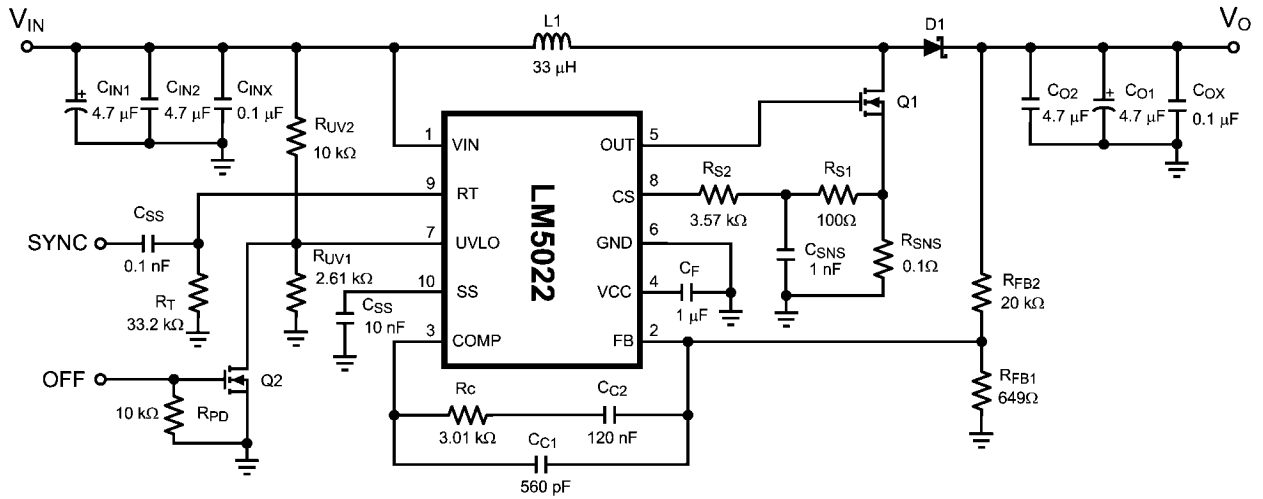

30001603

FIGURE 3. Circuit Schematic

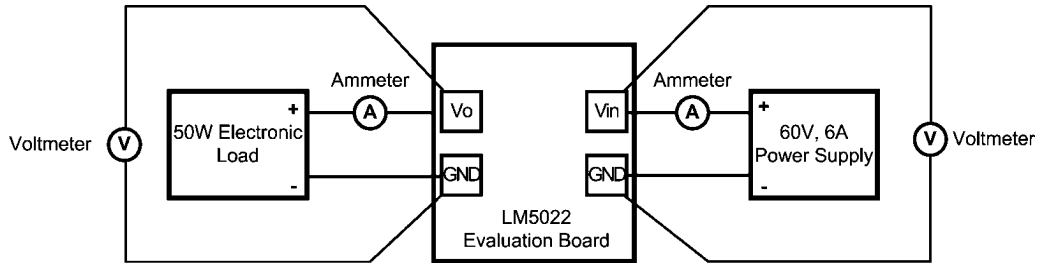

30001604

FIGURE 4. Efficiency Measurement Setup

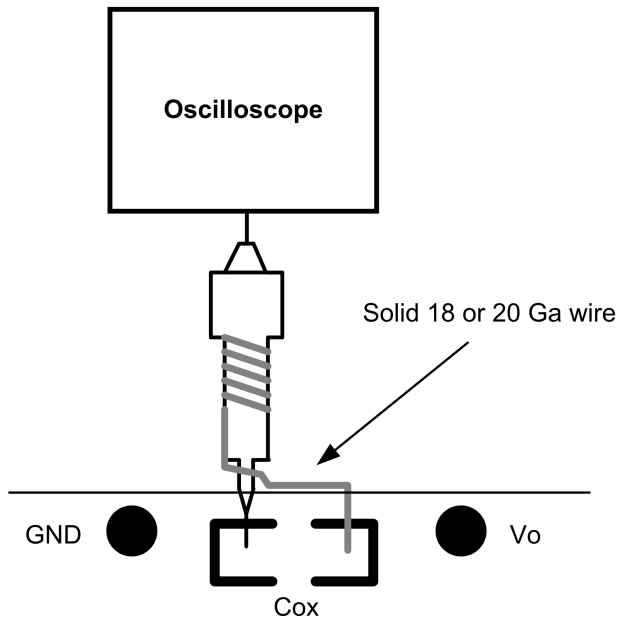

30001605

FIGURE 5. Output Voltage Ripple Measurement Setup

Typical Performance Characteristics

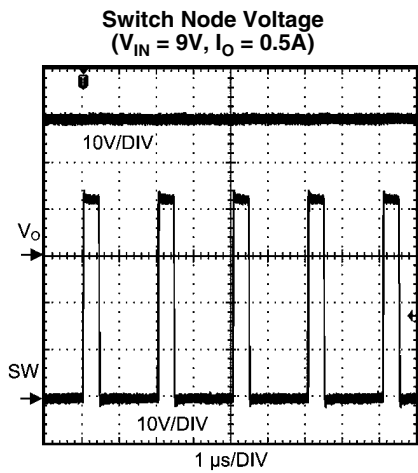

30001606

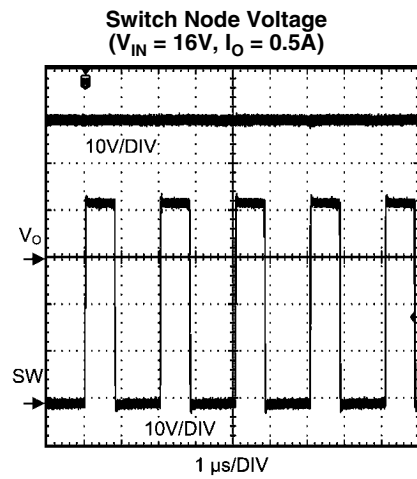

30001607

Output Voltage Ripple AC Coupled
 ($V_{IN} = 9V, I_O = 0.5A$)

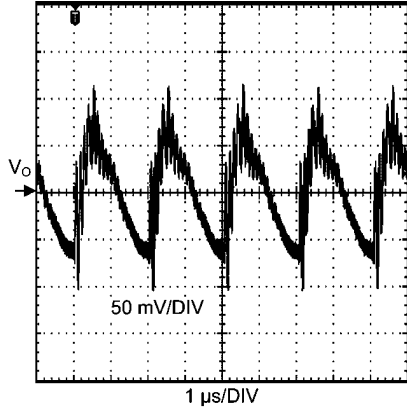

30001608

Output Voltage Ripple AC Coupled
 ($V_{IN} = 16V, I_O = 0.5A$)

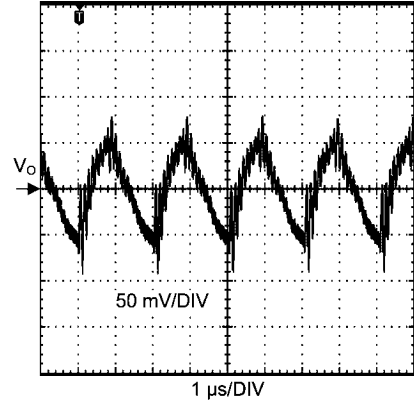

30001609

Load Transient Response
 ($V_{IN} = 9V, I_O = 50\text{ mA to }0.5A$)

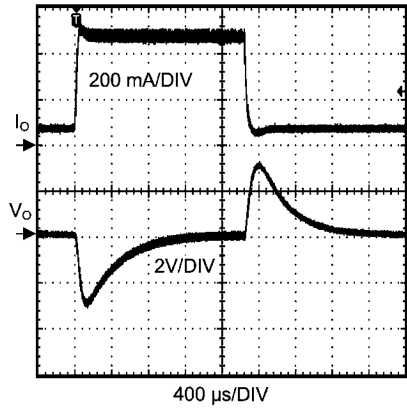

30001610

Load Transient Response
 ($V_{IN} = 16V, I_O = 50\text{ mA to }0.5A$)

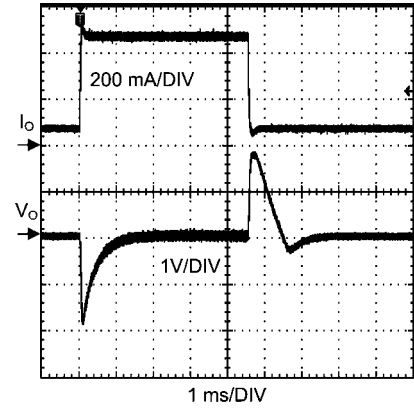

30001611

Start Up
 ($V_{IN} = 9V, I_O = 0.5A$)

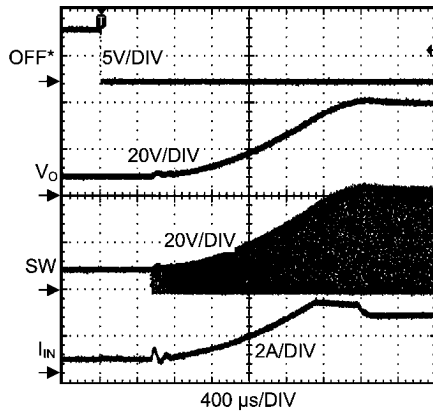

30001612

Shutdown
 ($V_{IN} = 9V, I_O = 0.5A$)

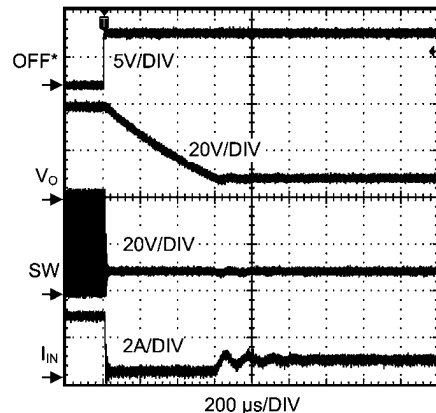

30001613

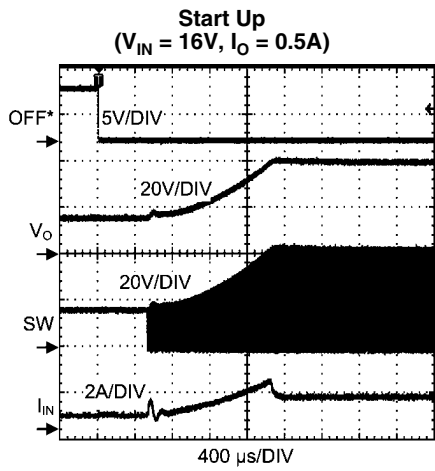

30001614

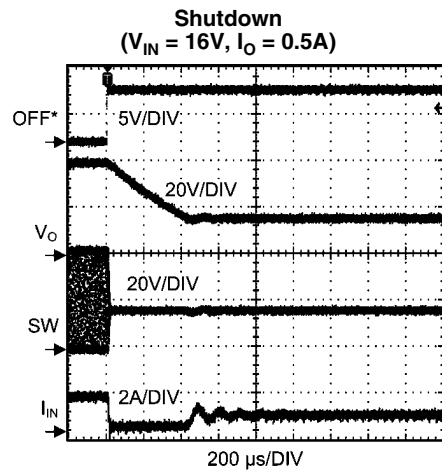

30001615

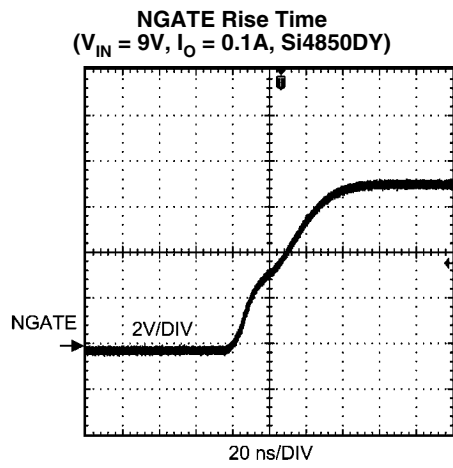

30001616

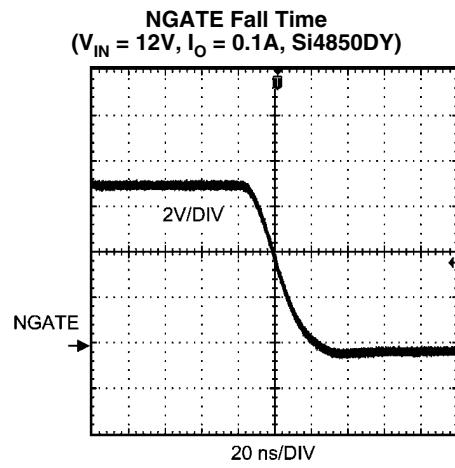

30001617

Bill of Materials

ID	Part Number	Type	Size	Parameters	Qty	Vendor
U1	LM5022	Low-Side Controller	MSOP-10		1	NSC
Q1	Si4850EY	MOSFET	SO-8	60V, 31mΩ, 27nC	1	Vishay
D1	CMSH2-60M	Schottky Diode	SMA	60V, 2A	1	Central Semi
L1	SLF12575T-330M3R2	Inductor	12.5x12.5 x7.5mm	33μH, 3.2A, 40mΩ	1	Pulse
Cin1 Cin2	C4532X7R1H475M	Capacitor	1812	4.7μF, 50V	2	TDK
Co1 Co2	C5750X7R2A475M	Capacitor	2220	4.7μF, 100V, 2mΩ	2	TDK
Cf	C3216X7R1E105K	Capacitor	1206	1μF, 25V	1	TDK
Cinx Cox	C2012X7R2A104M	Capacitor	0805	100nF, 100V	2	TDK
Cc1	VJ0805Y561KXXAT	Capacitor	0805	560pF 10%	1	Vishay
Cc2	VJ0805Y124KXXAT	Capacitor	0805	120nF 10%	1	Vishay
Css	VJ0805Y103KXXAT	Capacitor	0805	10nF 10%	1	Vishay
Csns	VJ0805Y102KXXAT	Capacitor	0805	1nF 10%	1	Vishay
Csyc	VJ0805A101KXXAT	Capacitor	0805	100pF 10%	1	Vishay
Rc	CRCW08053011F	Resistor	0805	3.01kΩ 1%	1	Vishay
Rfb1	CRCW08056490F	Resistor	0805	649Ω 1%	1	Vishay
Rfb2	CRCW08052002F	Resistor	0805	20kΩ 1%	1	Vishay
Rs1	CRCW0805101J	Resistor	0805	100Ω 5%	1	Vishay
Rs2	CRCW08053571F	Resistor	0805	3.57kΩ 1%	1	Vishay
Rsns	ERJL14KF10C	Resistor	1210	0.1Ω 1%, 0.5W	1	Vishay
Rt	CRCW08053322F	Resistor	0805	33.2kΩ 1%	1	Vishay
Ruv1	CRCW08052611F	Resistor	0805	2.61kΩ 1%	1	Vishay
Ruv1 Ruv2	CRCW08051002F	Resistor	0805	10kΩ 1%	1	Vishay
VIN, Vo GND GND2	160-1026	Terminal	0.094"		4	Cambion
GND3 GND4 OFF SYNC	160-1512	Terminal	0.062"		4	Cambion

PC Board Layout

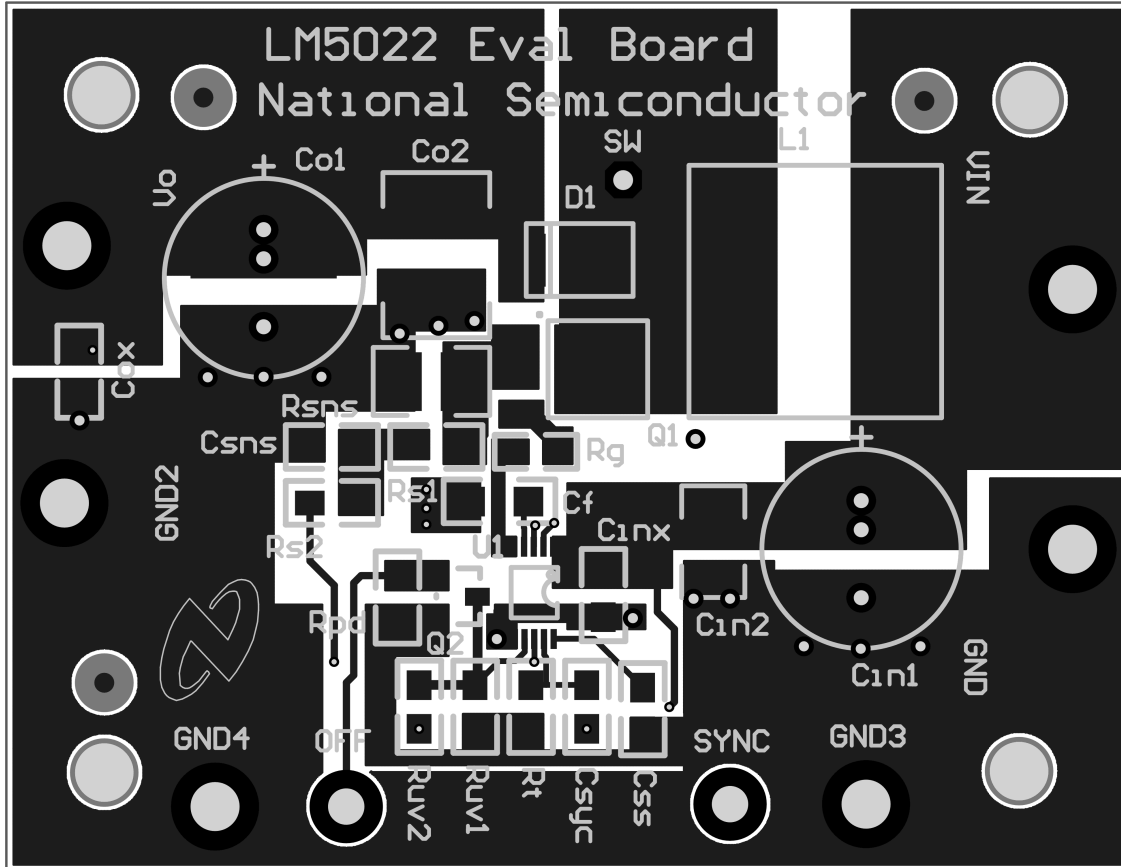

Top Layer and Top Overlay

30001618

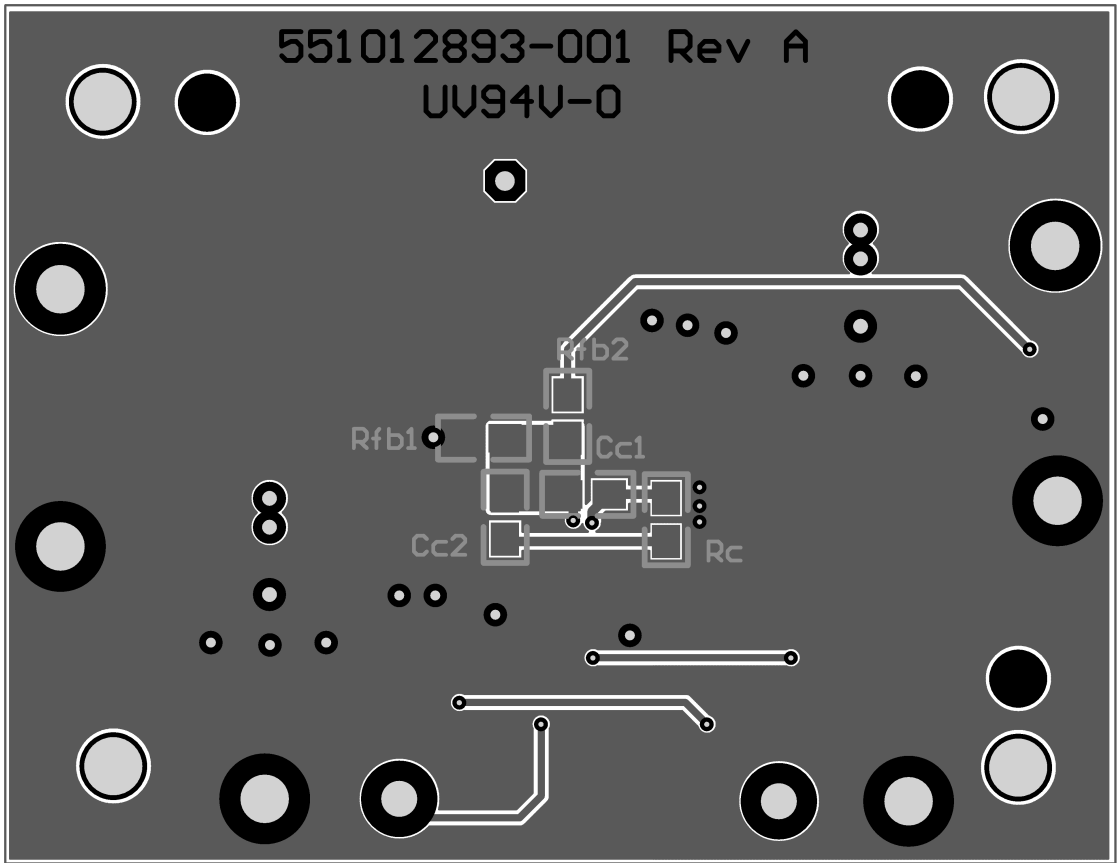

Bottom Layer

30001619

Notes

AN-1557

Notes

For more National Semiconductor product information and proven design tools, visit the following Web sites at:

Products		Design Support	
Amplifiers	www.national.com/amplifiers	WEBENCH	www.national.com/webench
Audio	www.national.com/audio	Analog University	www.national.com/AU
Clock Conditioners	www.national.com/timing	App Notes	www.national.com/appnotes
Data Converters	www.national.com/adc	Distributors	www.national.com/contacts
Displays	www.national.com/displays	Green Compliance	www.national.com/quality/green
Ethernet	www.national.com/ethernet	Packaging	www.national.com/packaging
Interface	www.national.com/interface	Quality and Reliability	www.national.com/quality
LVDS	www.national.com/lvds	Reference Designs	www.national.com/refdesigns
Power Management	www.national.com/power	Feedback	www.national.com/feedback
Switching Regulators	www.national.com/switchers		
LDOs	www.national.com/ldo		
LED Lighting	www.national.com/led		
PowerWise	www.national.com/powerwise		
Serial Digital Interface (SDI)	www.national.com/sdi		
Temperature Sensors	www.national.com/tempsensors		
Wireless (PLL/VCO)	www.national.com/wireless		

THE CONTENTS OF THIS DOCUMENT ARE PROVIDED IN CONNECTION WITH NATIONAL SEMICONDUCTOR CORPORATION ("NATIONAL") PRODUCTS. NATIONAL MAKES NO REPRESENTATIONS OR WARRANTIES WITH RESPECT TO THE ACCURACY OR COMPLETENESS OF THE CONTENTS OF THIS PUBLICATION AND RESERVES THE RIGHT TO MAKE CHANGES TO SPECIFICATIONS AND PRODUCT DESCRIPTIONS AT ANY TIME WITHOUT NOTICE. NO LICENSE, WHETHER EXPRESS, IMPLIED, ARISING BY ESTOPPEL OR OTHERWISE, TO ANY INTELLECTUAL PROPERTY RIGHTS IS GRANTED BY THIS DOCUMENT.

TESTING AND OTHER QUALITY CONTROLS ARE USED TO THE EXTENT NATIONAL DEEMS NECESSARY TO SUPPORT NATIONAL'S PRODUCT WARRANTY. EXCEPT WHERE MANDATED BY GOVERNMENT REQUIREMENTS, TESTING OF ALL PARAMETERS OF EACH PRODUCT IS NOT NECESSARILY PERFORMED. NATIONAL ASSUMES NO LIABILITY FOR APPLICATIONS ASSISTANCE OR BUYER PRODUCT DESIGN. BUYERS ARE RESPONSIBLE FOR THEIR PRODUCTS AND APPLICATIONS USING NATIONAL COMPONENTS. PRIOR TO USING OR DISTRIBUTING ANY PRODUCTS THAT INCLUDE NATIONAL COMPONENTS, BUYERS SHOULD PROVIDE ADEQUATE DESIGN, TESTING AND OPERATING SAFEGUARDS.

EXCEPT AS PROVIDED IN NATIONAL'S TERMS AND CONDITIONS OF SALE FOR SUCH PRODUCTS, NATIONAL ASSUMES NO LIABILITY WHATSOEVER, AND NATIONAL DISCLAIMS ANY EXPRESS OR IMPLIED WARRANTY RELATING TO THE SALE AND/OR USE OF NATIONAL PRODUCTS INCLUDING LIABILITY OR WARRANTIES RELATING TO FITNESS FOR A PARTICULAR PURPOSE, MERCHANTABILITY, OR INFRINGEMENT OF ANY PATENT, COPYRIGHT OR OTHER INTELLECTUAL PROPERTY RIGHT.

LIFE SUPPORT POLICY

NATIONAL'S PRODUCTS ARE NOT AUTHORIZED FOR USE AS CRITICAL COMPONENTS IN LIFE SUPPORT DEVICES OR SYSTEMS WITHOUT THE EXPRESS PRIOR WRITTEN APPROVAL OF THE CHIEF EXECUTIVE OFFICER AND GENERAL COUNSEL OF NATIONAL SEMICONDUCTOR CORPORATION. As used herein:

Life support devices or systems are devices which (a) are intended for surgical implant into the body, or (b) support or sustain life and whose failure to perform when properly used in accordance with instructions for use provided in the labeling can be reasonably expected to result in a significant injury to the user. A critical component is any component in a life support device or system whose failure to perform can be reasonably expected to cause the failure of the life support device or system or to affect its safety or effectiveness.

National Semiconductor and the National Semiconductor logo are registered trademarks of National Semiconductor Corporation. All other brand or product names may be trademarks or registered trademarks of their respective holders.

Copyright© 2008 National Semiconductor Corporation

For the most current product information visit us at www.national.com



**National Semiconductor
Americas Technical
Support Center**
Email: support@nsc.com
Tel: 1-800-272-9959

**National Semiconductor Europe
Technical Support Center**
Email: europe.support@nsc.com
German Tel: +49 (0) 180 5010 771
English Tel: +44 (0) 870 850 4288

**National Semiconductor Asia
Pacific Technical Support Center**
Email: ap.support@nsc.com

**National Semiconductor Japan
Technical Support Center**
Email: jpn.feedback@nsc.com